

### DATA SHEET

#### WIEGAND WIRE SENSOR WS-UTS-4-U0, WS-UFS-4-U0

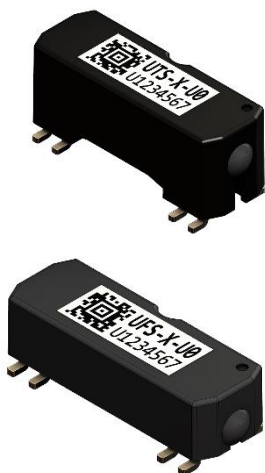

- ▶ Wiegand Wire Sensor for energy harvesting multiturn encoders using the Wiegand effect to generate energy from a rotating magnetic field<sup>1</sup>
- ▶ Optimized for operation with the multiturn counter module iC-PMX from iC-Haus
- ▶ In surface mounted technology suitable for reflow process, RoHS 2 compatible
- ▶ Versions for 2.5 mm and 5 mm wire distances from top of seating plane
- ▶ High Pulse energy with typical 170 nJ average pulse energy
- ▶ Machine readable serial number provides perfect traceability

### 1. Signal Characteristics

Item No.	Parameter	Symbol	Min.	Typ.	Max.	Unit	Remarks
101	Pulse peak-voltage	$U_P$	5.3	7.0		V	Valid for each trigger configuration i (Figure 5) with $U_{P_i, Average} - 4\sigma_i \geq U_{P, min}^*$ , analysis over 4*500 pulses @ 25 °C @ 6,8 ± 1% nF
102	Pulse slew rate	$S_R$	200			V/ms	@ 25 °C, 30% - 70% $U_P$
103	Pulse energy	$E_P$		170		nJ	@ 6,8 ± 1% nF
104	Temperature drift $V_{peak}$	$TC_P$		-0,008		V/K	

### 2. Electrical Characteristics

Item No.	Parameter	Symbol	Min.	Typ.	Max	Unit	Conditions
201	Coil resistance	R	250	270	290	$\Omega$	@25 °C, DC
202	Temp. Coefficient of Resistor	$TC_R$		$3,9 \cdot 10^{-3}$		1/K	
203	Coil inductance	L	10.5		14.5	mH	measured @ 1 kHz with magnet (polarity) parallel to wire axis.

### DATA SHEET

#### WIEGAND WIRE SENSOR WS-UTS-4-U0, WS-UFS-4-U0

<sup>1</sup> Devices and processes for energy harvesting by Wiegand wire within position encoders are protected by several worldwide patents (such as WO 2004/046735 A1) and require licensing by the inventors and applicants.

### 3. Environmental

Item No.	Parameter	Symbol	Min.	Typ.	Max	Unit	Conditions
301	Ambient operating temperature range	$T_a$	-40		+125	°C	
302	Relative humidity	rF			90%		No condensation
303	Shock Resitance	$S_r$			100	g	half sine 6 ms, EN 60068-2-27
304	Permanent shock resistance	$S_{rp}$			10	g	half sine 16 ms, EN 60068-2-29
305	Vibration Resistance	$V_r$			10	g	10 Hz-1000 Hz, EN 60068-2-6
306	Insulation Resistance	$R_{ISO}$	600			MΩ	Insulation resistance between pin and housing @ 1KV, FGluke 1577 isolation multimeter
307	Contact discharge	$D_c$			6	kV	IEC 61000-4-2
308	Air charge	$D_A$			8	kV	IEC 61000-4-2
309	Max. allowed external magnetic field to be applied to sensor not in operation	$B_{exmax}$			25	mT	e.g. important for storage and handling
310	Storage Temperature	$T_s$	-40		+85	°C	Recommended

### 4. Measurement Conditions

Item No.	Parameter	Symbol	Min.	Typ.	Max	Unit	Conditions
401	Magnetic flux density at wire	$B_w$	11.25		11.75	mT	Measured at wire axis
402	Distance magnet to wire	$W_d$	9.2	9.3	9.4	mm	Measured from wire axis to magnet surface (Figure 3)
403	x and y assembly tolerance		-0.15		0.15	mm	Measured from sensor centre – rotational axis
404	Magnet eccentricity				0.1	mm	
405	Load capacitor	$C_L$	6.7	6.8	6.9	nF	In parallel with IC-PMX(Figure 1)
406	Magnet rotation speed	$v$		1,000		rpm	
407	Input resistance	$R_M$		10		MΩ	Measurement device
408	Input capacitance	$C_M$		12		pF	Measurement device

#### Remarks

Magnet type: NdFeB diametral magnet, dimensions 7.5 x 4.0 mm (Figure 1), FRABA part number 10034019

### DATA SHEET

#### WIEGAND WIRE SENSOR WS-UTS-4-U0, WS-UFS-4-U0

Data measured under ideal measuring conditions. Test setup is isolated from external magnetic fields or other ferromagnetic components.

#### 5. Magnet System

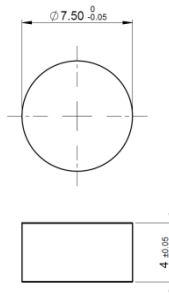

Figure 1

#### 6. Test Circuit

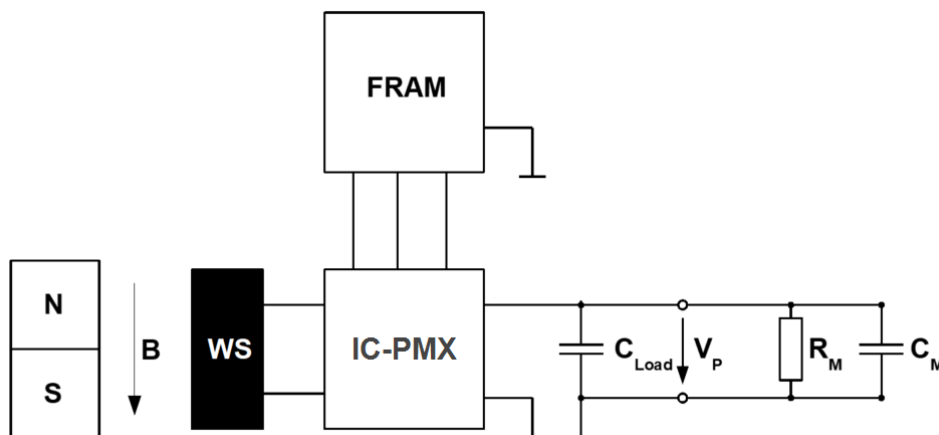

Figure 2

### DATA SHEET

#### WIEGAND WIRE SENSOR WS-UTS-4-U0, WS-UFS-4-U0

#### 7. Typical Signal Wave

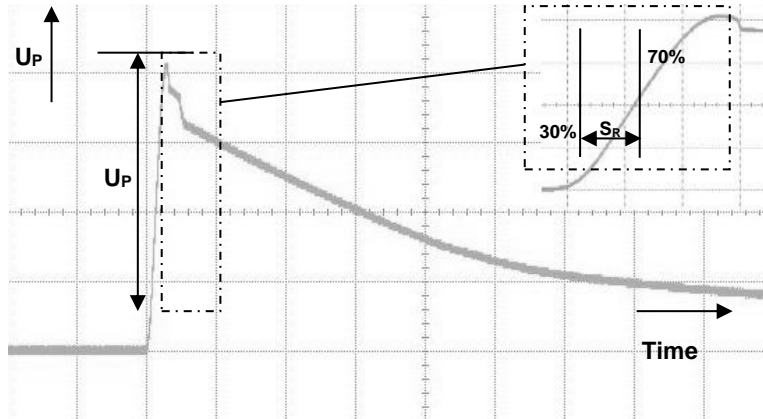

Figure 3

#### 8. Declaration Trigger Point

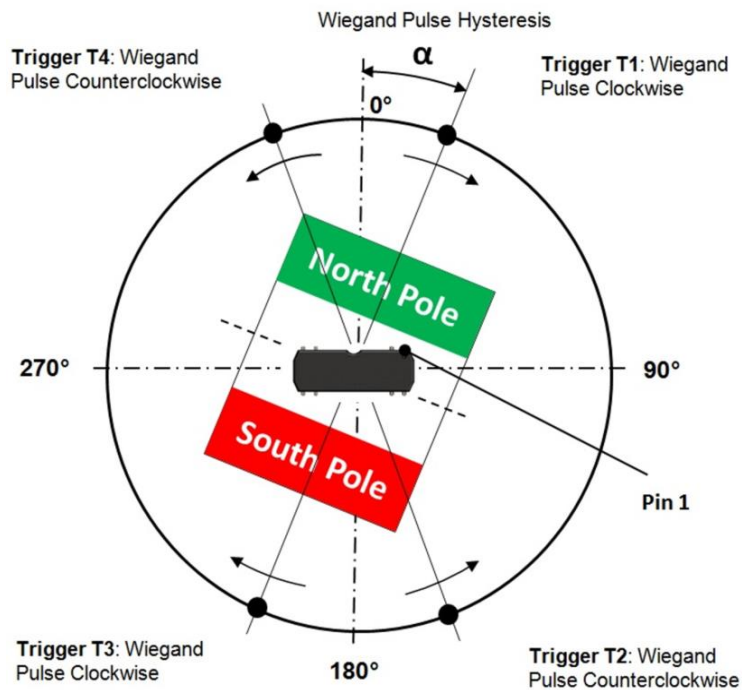
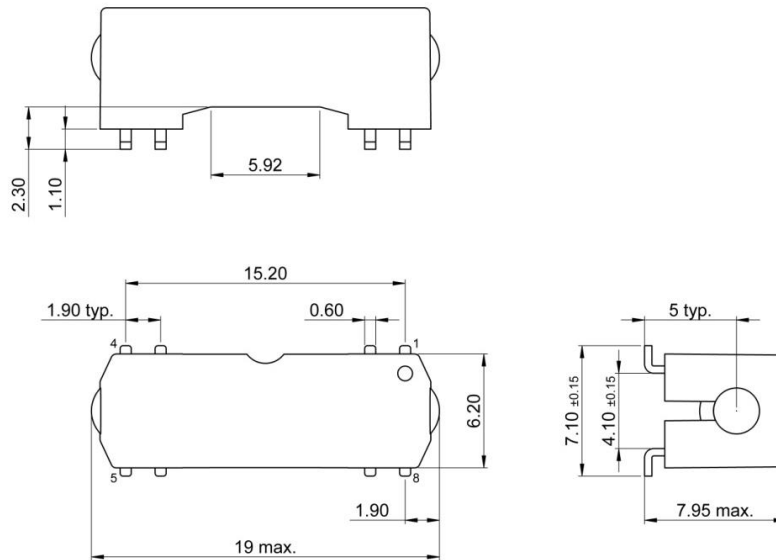

Figure 4

### DATA SHEET

#### WIEGAND WIRE SENSOR WS-UTS-4-U0, WS-UFS-4-U0

#### 9. Component Dimension Type: UTS-2



Coplanarity tolerance of leads 0.1 mm.  
All dimension in mm.

Figure 5

#### 10. Component Dimension Type: UFS-2

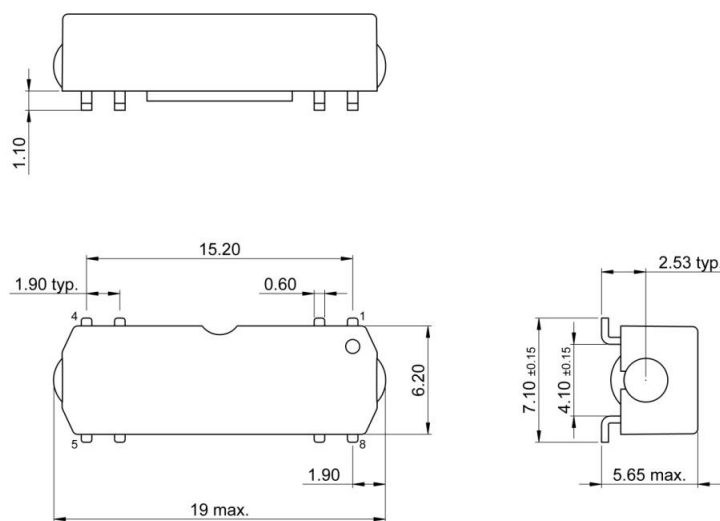

Coplanarity tolerance of leads 0.1 mm.  
All dimension in mm.

Figure 6

### DATA SHEET

#### WIEGAND WIRE SENSOR WS-UTS-4-U0, WS-UFS-4-U0

#### 11. Land Pattern Dimensions

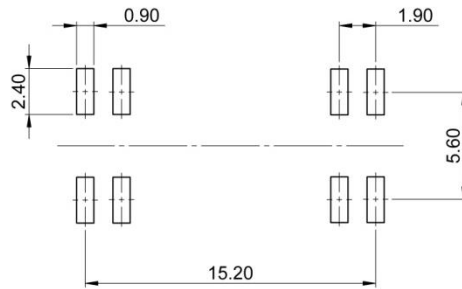

All dimension in mm.

Figure 7

Item No.	Parameter	Symbol	Min.	Typ.	Max	Unit	Conditions
1101	Sensor terminals			Pin 3 / Pin 4 and Pin 7 / Pin 8			Pin 3 / Pin 4: coil-winding end Pin 7 / Pin 8: coil-winding start Pin 1, 2, 5, 6 not used

#### Remarks

Pin material Cu tin plated, mass 0.029 g, results in a theoretical thermal energy surge of  $\Delta Q \approx 2 \text{ W}$  for each contact pin ( $390 \text{ W}/(\text{kg}\cdot\text{K})$  and  $\Delta T_{\text{reflow}}$  of 170 K.

SMD package, suitable for reflow process

RoHS 2 (2011/65/EU) Compatible

### DATA SHEET

#### WIEGAND WIRE SENSOR WS-UTS-4-U0, WS-UFS-4-U0

#### 12. Reflow Profile

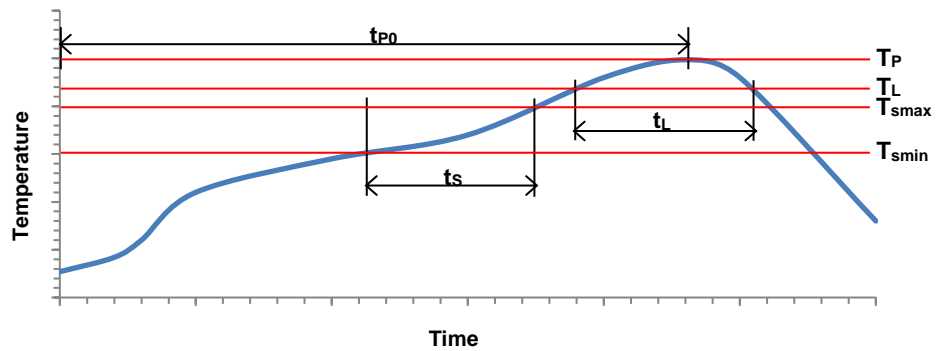

Figure 8

Item No.	Parameter	Symbol	Min.	Typ.	Max	Unit	Conditions
1201	Liquidous temperature	$T_L$		217		°C	Soldering paste material: Sn95.5Ag4Cu0.5
1202	Time maintained above $T_L$	$t_L$		60		s	
1203	Peak package body temperature	$T_P$		249		°C	
1204	Time 25 °C to $T_P$	$t_{p0}$		230		s	
1205	Preheat / Soak temperature min	$T_{smin}$		150		°C	
1206	Preheat / Soak temperature max	$T_{smax}$		200		°C	
1207	Time from $T_{smin}$ to $T_{smax}$	$t_s$		70		s	
1208	Ramp-up rate ( $T_L$ to $T_P$ )			0.9	3	K / s	
1209	Ramp-down rate ( $T_P$ to $T_L$ )			1.3	6	K / s	
1210	Reflow soldering speed	$v_s$		1000.0		mm / min	reflow soldering machine: Linie VX-nitro-3500 (Type 734)

### DATA SHEET

#### WIEGAND WIRE SENSOR WS-UTS-4-U0, WS-UFS-4-U0

#### 13. Labelling Information

Type and Serial number

Serial Number in Aztec Code



Figure 9

#### 14. Packaging Information

13-inch reel.

Max. 700 pcs./reel

Connectors across to reel.

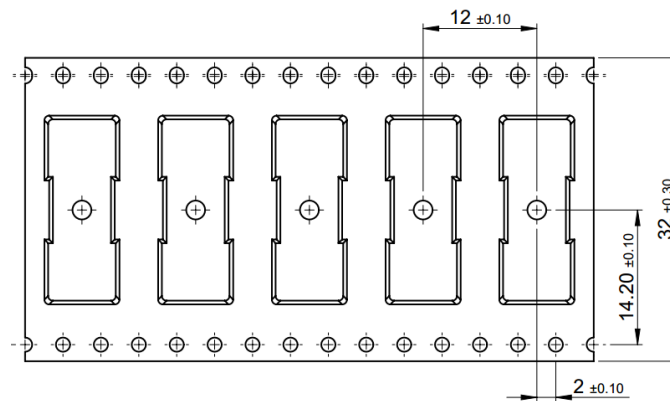

Figure 10

#### 15. Ordering Information

Article Name	Article Number
WS-Sensor-WS-UTS-4-U0 on Reel	10046624
WS-Sensor-WS-UFS-4-U0 on Reel	10046623



### DATA SHEET

#### WIEGAND WIRE SENSOR WS-UTS-4-U0, WS-UFS-4-U0

#### 16. Revision History

Rev.:	Date	BY	Remarks
2.0	26.09.2017	MFO	Created UBITO standard product data sheet, copy version 1.6
2.1	12.10.2017	MFO	Updated product pictures
2.2	19.10.2017	MFO	Updated product pictures
2.3	20.10.2017	MFO	Minor corrections: Titles chapter 9 and 10 Label on product pictures Modified figure 4
2.4	29.06.2018	TBE	Updated 203 Coil inductance and clarified conditions to "measured @10 kHz with magnet (polarity) parallel to wire axis." 309 "Max. magnetic field exposure" wording changed to "Max. allowed external magnetic field to be applied to sensor not in operation" Added tray packing details Contact address for technical support team updated 403 definition changed to "x and y assembly tolerance"

Editor: TBE

Reviewer: RRU, MLO

Date: 29.06.2018

Module Type: WS-UTS-2-U0, WS-UFS-4-U0

### DATA SHEET

#### WIEGAND WIRE SENSOR WS-UTS-4-U0, WS-UFS-4-U0

#### Contact

FRABA America

T +1 609 750-8705

[info@posital.com](mailto:info@posital.com)

FRABA Europe

T +49 221 96213-0

[info@posital.eu](mailto:info@posital.eu)

FRABA Asia

T +65 6514 8880

[info@posital.sg](mailto:info@posital.sg)

All dimension in [inch] mm. This drawing and the information contained is for general presentation purposes only. Please refer to the "Download" section for detailed technical drawings.

© FRABA B.V., All rights reserved. We do not assume responsibility for technical inaccuracies or omissions. Specifications are subject to change without notice.